

HSS

HSSE

TiN

Conical peeling drills
Schälbohrer
Конические сверла

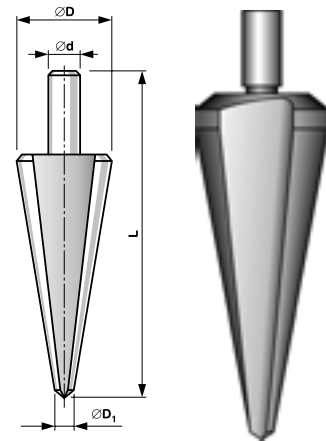

Velikost/Size/Größe/Размер

D₁

D

Ø d

L

code HSS

code HSSE

3/14 (č. 1)

3,5

14

6

58

541 140

544 140

6/20 (č. 2)

6

20

8

66

541 200

544 200

3/22 (č. 2A)

3,5

22,5

8

72

541 225

544 225

9/22

9,5

22,5

10

66

541 230

544 230

4/30

4

30

10

103

541 250

544 250

6/30 (L)

6

30

10

103

541 300

544 300

8/30

8

30

10

97

541 260

544 260

Velikost/Size/Größe/Размер

D₁

D

Ø d

L

code HSS TiN

code HSSE TiN

3/14 (č. 1)

3,5

14

6

58

546 140 TiN

596 140 TiN

6/20 (č. 2)

6

20

8

66

546 200 TiN

596 200 TiN

3/22 (č. 2A)

3,5

22,5

8

72

546 225 TiN

596 225 TiN

9/22

9,5

22,5

10

66

546 230 TiN

596 230 TiN

4/30

4

30

10

103

546 250 TiN

596 250 TiN

6/30 (L)

6

30

10

103

546 300 TiN

596 300 TiN

8/30

8

30

10

97

546 260 TiN

596 260 TiN

HSS**HSSE****TiN**

Conical peeling drills
Schälbohrer
Конические сверла

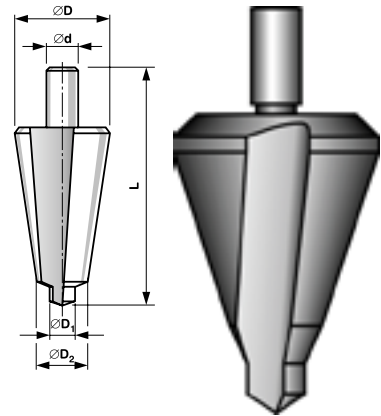

Velikost/Size/Größe/Размер	D ₂	D	Ø D ₁	Ø d	L	code HSS	code HSSE
16/30 (č. 3)	16	30	10	10	75	542 300	545 300
26/40 (č. 4)	26	40	10	12	85	542 400	545 400
36/50 (č. 5)	36	50	14	13	87	542 500	545 500
40/60 (č. 6)	40	61	16	13	100	542 600	545 600

Velikost/Size/Größe/Размер	D ₂	D	Ø D ₁	Ø d	L	code HSS TiN	code HSSE TiN
16/30 (č. 3)	16	30	10	10	75	547 300 TiN	597 300 TiN
26/40 (č. 4)	26	40	10	12	85	547 400 TiN	597 400 TiN
36/50 (č. 5)	36	50	14	13	87	547 500 TiN	597 500 TiN
40/60 (č. 6)	40	61	16	13	100	547 600 TiN	597 600 TiN

Materiál: HSS; HSSE; TiN

Material: HSS; HSSE; TiN

Werkstoff: HSS; HSSE; TiN

Mamepuan: HSS; HSSE; TiN

HSS**HSSE****TiN**

Conical peeling drills
Schälbohrer
Конические сверла

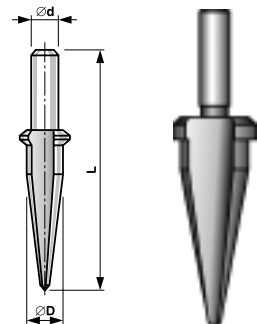

Velikost/Size/Größe/Размер	Ø D	Ø d	L	code HSS	code HSSE
1/7,8	7,8	6	49	543 078	593 078
2/10,2	10,2	6	53	543 102	593 102

**BUČOVICE
TOOLS**

Materiál: HSS; HSSE

Material: HSS; HSSE

Werkstoff: HSS; HSSE

Mamepuan: HSS; HSSE

HSS

Conical peeling drills
 - bits
 Schälaufbohrer - Bits
 Конические сверла
 - БИТЫ

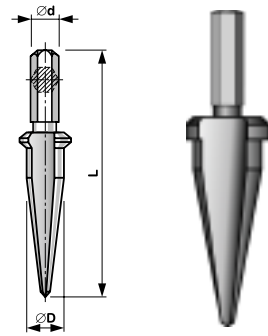

Velikost/Size/Größe/Размер	Ø D	Ø d	L	code
3/7	3-7	1/4"	40	540 070
3/14	3-14	1/4"	58	540 140

Materiál: HSS

Material: HSS

Werkstoff: HSS

Mamepuan: HSS

NO

Cutting disks
 Schneidräder
 Отрезные диски

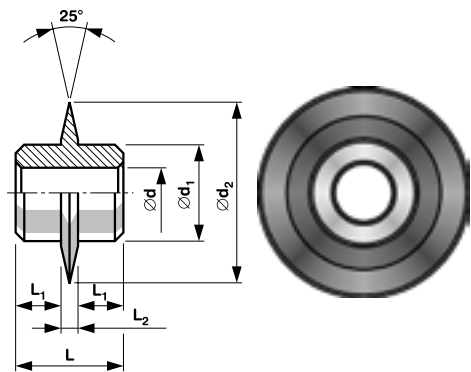

	Typ	d/H9	d ₁	d ₂	L ₁	L ₂	L	code
1	MZ-2	9	17	35	7,75	3,5	19	840 001
2	REMS Combi	9	17	32	8	3	19	840 002
3	OSTER	8,87	17	32	8	3	19	840 003
4	RIDGID 300	8,87	17	32	8	3	19	840 004

Materiál: NO

Material: CS

Werkstoff: WS

Mamepuan: NO